

# Poulies synchrones de serrage à couple élevé - S3M, S5M, S8M

■ **Caractéristiques** : peuvent facilement être assemblé à un arbre par boulonnages. Positionnement facile.



RoHS10

HTCPA  S3M060  
S3M100  
(Pas 3.0mm)

HTCPA  S5M100  
S5M150  
(Pas 5.0mm)

HTCPA  S8M150  
S8M250  
(Pas 8.0mm)

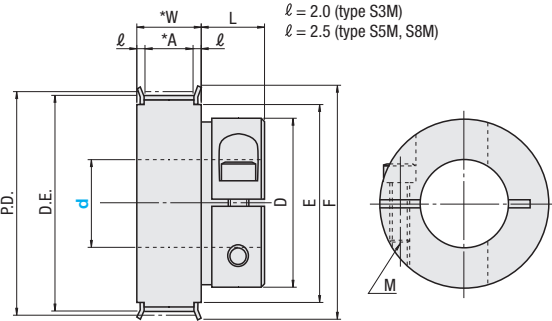

Profil de dent standard

**S3M**

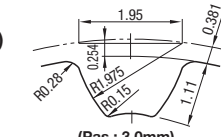

(Pas : 3.0mm)

**S5M**

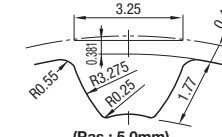

(Pas : 5.0mm)

**S8M**

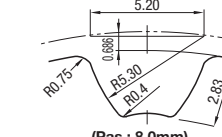

(Pas : 8.0mm)

■ **Tolérance d'arbre recommandée h7 (g6)**

⚠ Rugosité de la surface de finition : Ra = 3.2a max.

Type	Matériau	Traitement de surface
HTCPA	EN AW-7075 équiv. / Alage d'aluminium 99.9900	Anodisé clair

\* L'embase est installée.  
\* Vis d'assemblage à tête à six pans creux incluses. (EN 1.7220 équiv., oxyd. noir)    ⚠ Les alésages d'arbre peuvent ne pas avoir fait l'objet d'un traitement de surface. Les dimensions de la gorge des dents varient légèrement en fonction du nombre de dents

■ **S3M** Pour les courroies de distribution à couple élevé, voir **P.1465.**

Référence pièce		Sélection d	P.D.	D.E.	D	F	E	L	Vis de collier		Prix unitaire	
Type	Nombre de dents								M	Couple de serrage (N·m)	S3M060	S3M100
HTCPA	24	4	22.92	22.16	13	25	16	9	2	0.4		
	26	4	24.83	24.07		28	18					
	28	4	26.74	25.98		30	20					
	30	6 8	28.65	27.89	32	23						
	32	6 8	30.56	29.80	35	25						
	36	6 8	34.38	33.62	40	28						
	40	8 10	38.20	37.44	44	32	12.5	3	1.5			
	44	8 10	42.02	41.25	48	36						
	48	8 10 11 12	45.84	45.07	50	38						
	50	8 10 11 12 13 14	47.75	46.98	52	40	14	4	3.5			
	60	8 10 11 12 13 14 15 16	57.30	56.53	61	46				15.5	5	6

■ **S5M** Pour les courroies de distribution à couple élevé, voir **P.1465.**

Référence pièce		Sélection d	P.D.	D.E.	D	F	E	L	Vis de collier		Prix unitaire			
Type	Nombre de dents								M	Couple de serrage (N·m)	S5M100	S5M150	S5M100	S5M150
HTCPA	24	8 10	38.20	37.24	26	45	30	12.5	3	1.5				
	25	8 10	39.79	38.83										
	26	8 10	41.38	40.42										
	28	8 10	44.56	43.60										
	30	10	47.75	46.79										
	32	10 11 12 13 14	50.93	49.97										
	34	10 11 12 13 14 15 16	54.11	53.15	14	4	3.5							
	36	10 11 12 13 14 15 16	57.30	56.34										
	40	10 11 12 13 14 15 16 17 18 19	63.66	62.70	41	61	45	15.5	5	6				
	44	12 13 14 15 16 17 18 19	70.03	69.07										
	48	20 21 22 23 24	76.39	75.43										
	50	12 13 14 15 16 17 18 19	79.58	78.62										
	60	20 21 22 23 24 25	95.49	94.53										
					46	74	58				15.5	5	6	
					55	83	63	16.5	6	12				
					46	83	63	15.5	5	6				
					55	87	67	16.5	6	12				
					46	87	67	15.5	5	6				
					55	99	80	16.5	6	12				
					55			16.5	6	12				

■ **S8M**

■ Pour les courroies de distribution à couple élevé, voir **P.1465.**

Référence pièce		Sélection d	P.D.	D.E.	D	F	E	L	Vis de collier		Prix unitaire		
Type	Nombre de dents								M	Couple de serrage (N·m)	S8M150	S8M250	
HTCPA	20	12 13 14	50.93	49.56	36	58	40	14	4	3.5			
	22	12 13 14 15 16	56.02	54.65	41	61	45	16	5	6			
	24	12 13 14 15 16 17 18 19	61.12	59.74	46	67	50						
	25	12 13 14 15 16 17 18 19	63.66	62.29	46	70	56						
	28	*A:17 *W:22	15 16 17 18 19	71.30	69.93	55	80	60	17	6	12		
	S3M	30	15 16 17 18 19	76.39	75.02	46	87	67	16	5	6		
			20 21 22 23 24 25			55			17	6	12		
			18 19			46			16	5	6		
		32	20 21 22 23 24 25	81.49	80.12	55	17	6	12				
			18 19			46	16	5	6				
			20 21 22 23 24 25			55	17	6	12				
	34	18 19	86.58	85.21	46	95	75	16	5	6			
		20 21 22 23 24 25			55	17	6	12					
	36	18 19	91.67	90.30	46	99	80	16	5	6			
		20 21 22 23 24 25			55	17	6	12					

■ **Couple admissible (S3M)**

Type	Nombre de dents	Diam. de l'arbre	Couple admissible (N·m)
S3M	24 26 28	4	0.16
	30 32	6	0.95
		8	2.6
		10	0.95
	36	8	2.6
		10	2.6
	40	8	2.6
		10	2.6
		12	2.6
	44	8	2.6
		10	2.6
		12	2.6
		14	2.6
	48	8	2.6
		10	2.6
		11	2.6
12		2.6	
13		2.6	
14		7.6	
50	8	2.6	
	10	2.6	
	11	2.6	
	12	2.6	
	13	2.6	
	14	7.6	
60	8	2.6	
	10	2.6	
	11	2.6	
	12	2.6	
	13	2.6	
	14	7.6	
	15	7.6	
	16	7.6	

■ **Couple admissible (S5M)**

Type	Nombre de dents	Diam. de l'arbre	Couple admissible (N·m)
S5M	24 25	8	2.6
		10	2.6
	26 28	8	2.6
		10	2.6
		12	2.6
	30	10	2.6
		11	2.6
		12	2.6
		13	2.6
	32	14	7.6
		10	2.6
		11	2.6
		12	2.6
		13	2.6
		14	7.6
	34 36	10	2.6
		11	2.6
		12	2.6
		13	2.6
		14	7.6
		15	7.6
	40	10	2.6
		11	2.6
		12	2.6
13		2.6	
14		7.6	
15		7.6	
16		7.6	
17		7.6	
18		7.6	
19		7.6	
20		7.6	
21		7.6	
44 48 50 60	12	2.6	
	13	2.6	
	14	2.6	
	15	7.6	
	16	7.6	
	17	7.6	
	18	7.6	
	19	7.6	
	20	48	
	21	66	
	22	66	
	23	66	
24	95		
25	95		

■ **Couple admissible (S8M)**

Type	Nombre de dents	Diam. de l'arbre	Couple admissible (N·m)
S8M	20	12	2.6
		13	7.6
		14	7.6
	22	12	2.6
		13	2.6
		14	7.6
		15	7.6
	24 25	16	2.6
		12	2.6
		13	2.6
		14	7.6
		15	7.6
16		7.6	
28 30	17	7.6	
	18	7.6	
	19	7.6	
	20	48	
	21	66	
	22	66	
	23	66	
	24	95	
	25	95	
	32 34 36	18	7.6
		19	7.6
		20	48
21		48	
22		66	
23		66	
24		95	
25		95	



**Ordering Example**

Référence pièce		Diam. de l'alésage de l'arbre d
Type	Nombre de dents - Type, largeur nominale	
HTCPA40	- S3M060 - 10	