

Poignées de tirage cintrées/Poignées de tirage moulées

Montage extérieur



Poignées de tirage rabattables / Poignées de tirage avec cache / Poignées de tirage à tube aluminium

Montage extérieur

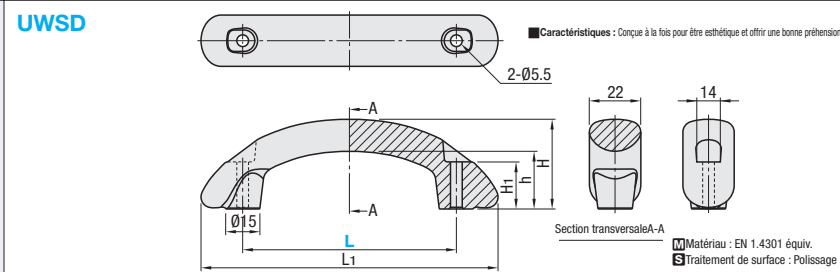

Référence pièce		L1	H	h	H1	Charge admissible (N)	Masse (g)	Prix unitaire
Type	L							
UWSD	100	139	42	27	21	500	337	
	150	190	44	29	17		434	

Ordering Example
Référence pièce
UWSD150

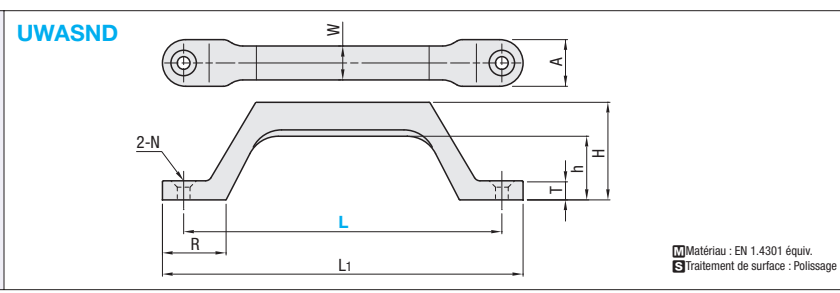

Référence pièce		L1	H	h	T	A	W	R	N		Charge admissible (N)	Masse (g)	Prix unitaire
Type	L								Trou	Chanfrein			
UWASND	80	96	32	20	6	18	12	20	4.5	8.5	500	97	
	100	116						23				116	
	150	170	46	30	9	22	16	30	6.5	12.5		301	
	200	220	46	30	9	22	16	30	6.5	12.5		354	

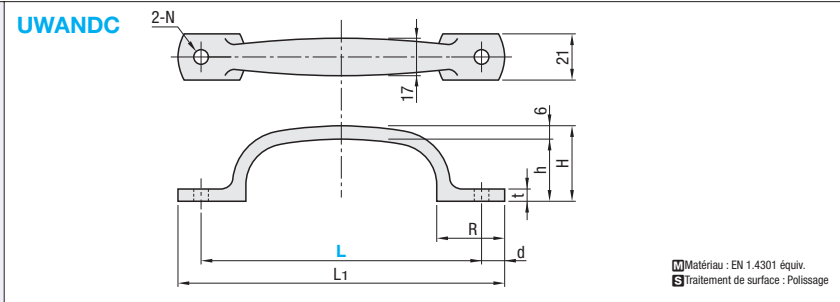

Référence pièce		L1	H	h	t	R	d	N	Charge admissible (N)	Masse (g)	Prix unitaire
Type	L										
UWANDC	105	120	30	24	5	25	7.5	5.5	500	83	
	115	130	33	27	5	26	7.5	5.5		90	
	125	145	34	28	5.5	30	10	6.5		106	

Ordering Example
Référence pièce
UWASND100
UWANDC125

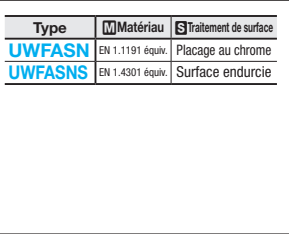

Référence pièce		L1	Charge admissible (N)	Masse (g)	Prix unitaire	
Type	L				UWFASN	UWFASNS
UWFASN (acier)	138	100	650	150		
	158	120	550	160		
	180	142	520	180		
	218	180	500	200		

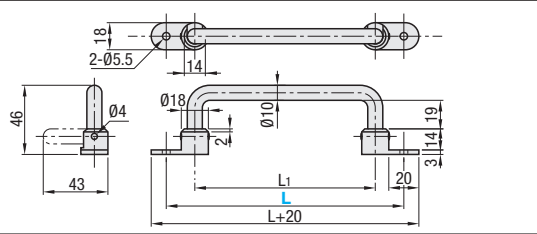

Ordering Example
Référence pièce
UWFASN138

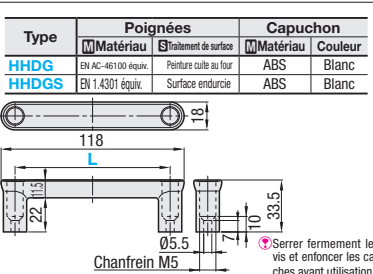

Référence pièce		L	Masse (g)	Vis applicable		Prix unitaire	
Type	L			Vis	Qté	HHDG	HHGDS
HHDG	HHGDS	100	62	Vis à tête plate M5	2		

Ordering Example
Référence pièce
HHDG100

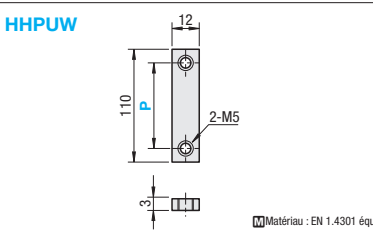

Référence pièce		P	Poignée utilisable	Prix unitaire	
Type	P			1 à 9 pièce(s)	10~100
HHPUW	HHPUW	100	HHDG100		
			HHGDS100		

Ordering Example
Référence pièce
HHPUW100

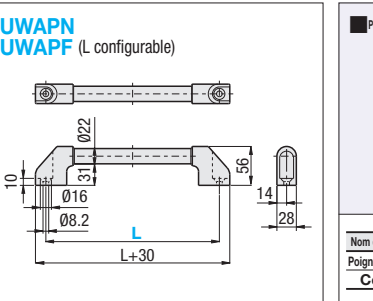

Référence pièce		L	Vis applicable	Prix unitaire
Type	L			
UWAPN (L fixe)	150		Vis à tête plate M8	
	200			
	250			
	300			
	400			
	500			
UWAPF (L configurable)	100-150	incrément de 1mm	Vis à tête plate M8	
	151-200			
	201-250			
	251-300			
	301-400			
	401-500			
501-600				

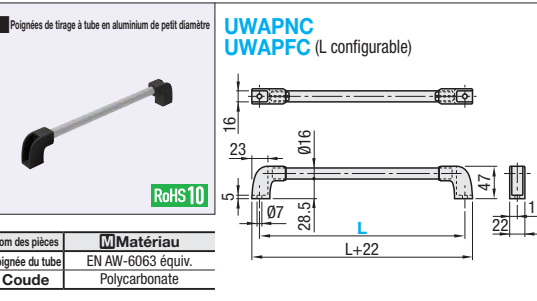

Référence pièce		L	Vis applicable	Prix unitaire
Type	L			
UWAPNC (L fixe)	100		Vis d'assemblage à tête à six pans creux M6	
	150			
	200			
	250			
	300			
UWAPFC (L configurable)	100-150	incrément de 1mm	Vis d'assemblage à tête à six pans creux M6	
	151-200			
	201-250			
	251-300			

Ordering Example
Référence pièce - L
UWAPN 150
UWAPFC 185

* n'est pas nécessaire pour le type à dimension L fixe.