

# CARBIDE PUNCHES WITH KEY GROOVES

—TiCN COATING—

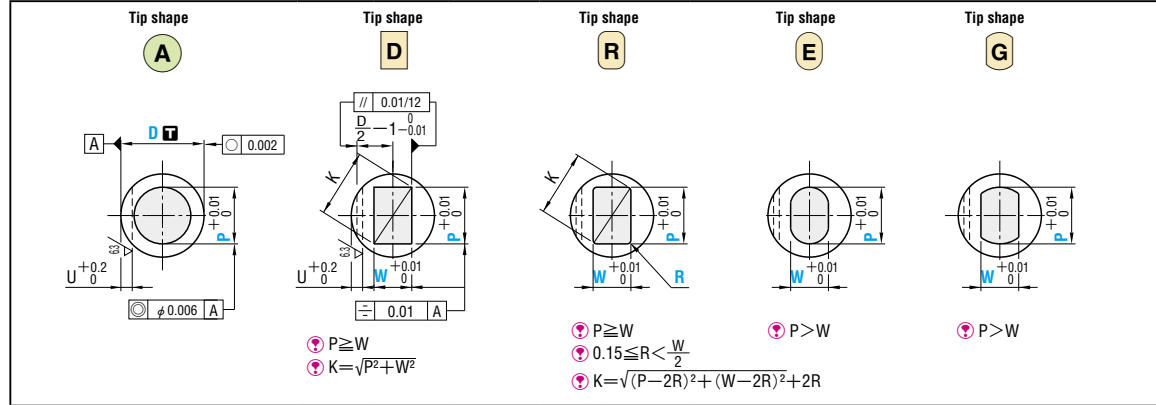

Type	Shank diameter D Tolerance	M H	Catalog No.		The tip shape can be selected from tip shapes A ~ G in the figure below.
			Type	Tip shape B Tip length	
—TiCN coating— <b>RoHS</b>	D <sub>m5</sub>	V30 (HIP) 88 ~ 89HRA Surface 3000HV	H—WK	A	<p>The tip end is ground before the coating is applied. Although the marks of processing may remain in the center of a flange end face, it is satisfactory on a function.</p>
			H—W XK (D3 ~ 6)	D	
	AH—WK	E			
	AH—W XK (D3 ~ 6)	G			
	D <sup>+0.005</sup> <sub>0</sub>	V30 (HIP) 88 ~ 89HRA Surface 3000HV			
		Super fine grain (HIP) 90 ~ 92HRA Surface 3000HV			



Type	Tip shape	B Tip length	D	0.01mm increments					R	T	B	U Key groove depth		
				L										
				min. P	max.	P · Kmax.	P · Wmin.							
(D <sub>m5</sub> ) H—WK H—W XK (D3 ~ 6)	A D R	S	3	40	50	60	70	1.00 ~ 2.99	—	—	0.15 ≤ R < W/2 T ≥ 5.0	8	0.5	
			4	40	50	60	70	1.00 ~ 3.99	3.97	1.50				
			5	40	50	60	70	2.00 ~ 4.99	4.97	1.50				
			6	40	50	60	70	2.00 ~ 5.99	5.97	1.50				
			8	(40)	50	60	70	80	3.00 ~ 7.99	7.97				2.00
			10	(40)	50	60	70	80	3.00 ~ 9.99	9.97				2.50
(D <sup>+0.005</sup> ) AH—WK AH—W XK (D3 ~ 6)	E G	L	3	50	60	—	—	—	—	—	0.15 ≤ R < W/2 T ≥ 5.0	13	0.5	
			4	50	60	70	1.00 ~ 3.99	3.97	2.00					
			5	50	60	70	2.00 ~ 4.99	4.97	2.00					
			6	50	60	70	2.00 ~ 5.99	5.97	2.00					
			8	50	60	70	80	3.00 ~ 7.99	7.97	2.50				
			10	50	60	70	80	3.00 ~ 9.99	9.97	2.50				
			13	50	60	70	80	6.00 ~ 12.99	12.97	3.00				
			16	60	70	80	10.00 ~ 15.99	15.97	4.00					

L(40) → B=8 If full length is (40), tip length is 8mm in all cases.  
If no key groove is required, select T=L.

Order Catalog No. — L — P — W — R(®) only — T If no key groove is required, select T=L.  
H—WKAS 8 — 70 — P6.50 — T20

Days to Ship **Quotation**

Alterations Catalog No. — L(LC-LCT) — P(PC) — W(WC) — R — T — (BC-KC-KD, etc.)  
H—WKAS 8 — LC65.5 — P6.50 — T20 — TKC

Alteration	Code	A	D R E G	1Code
Alterations to tip	PC WC	Tip dimension change PC ≥ Pmin/2 ≥ 1.00 0.01mm increments (If combined with PKC, 0.001mm increments can be selected.) ⊗ Cannot be used for D3-4.	Tip dimension change WC ≥ Pmin × 2/3 ≥ 1.00 0.01mm increments	
	BC	Tip length change 2 ≤ BC ≤ Bmax ≤ L/2 0.1mm increments ⊗ Full length L must be at least 25mm longer than tip length BC.	Tip length change 2 ≤ BC ≤ Bmax. 0.1mm increments ⊗ Full length L must be at least 30mm longer than tip length BC.	
	SC	Tip roughness change The base material is finished before the coating is applied.		
	PRC	Rounding of tip side edge 0.3 ≤ PRC ≤ 1 0.1mm increments ⊗ PRC ≤ (P-0.2)/2 ⊗ Cannot be combined with PCC-GC.		
	PCC	Chamfering to tip side edge 0.3 ≤ PCC ≤ 1 0.1mm increments ⊗ PCC ≤ (P-0.2)/2 ⊗ Cannot be combined with PRC-GC.		
	GC	20° ≤ GC < 90° 1° increments Tip length B ≥ f+2 f = P/2 × tan(90° - GC°) ⊗ If combined with SC, tip edges are rounded. ⊗ Cannot be used for P ≤ 1.00. ⊗ Cannot be combined with LKC-LCT-PRC-PCC.		
Alterations to full length	LK	Full length change 25+B(BC) ≤ LC < L 0.1mm increments ⊗ If difference between full length and tip length is 25mm or less, tip length is adjusted to (Full length-25mm). (If combined with LKC, 0.01mm increments can be selected.)	Full length change 30+B(BC) ≤ LC < L 0.1mm increments ⊗ If difference between full length and tip length is 30mm or less, tip length is adjusted to (Full length-30mm). (If combined with LKC, 0.01mm increments can be selected.)	
	LCT TKC	T dimension tolerance change T +0.05 → -0.02	Full length tolerance change L +0.3 → +0.1	
Others	LKC	Full length tolerance change L +0.3 → +0.05		
	KC	Key flat position change 1° increments		
	NKC	No key flat		
	KD	Key groove 180° position change 1° increments		
	WKD	Addition of double key grooves in parallel	Double key grooves in parallel. Can be combined with KD.	
	TKC	T dimension tolerance change T +0.05 → -0.02		
Alterations to shank	UK	Key groove depth change ⊗ Cannot be used for D3.		
	SKC	Single key flat on shank ⊗ D3 ~ 6 P ≤ D-1.2 W ≤ D-1.2 (Machining width 0.5) ⊗ D8 ~ P ≤ D-2.2 W ≤ D-2.2 (Machining width 1) ⊗ Cannot be combined with KC-KD-WKD.		

Price **Quotation**

